



# PANEL5000-C152-L

A1 Touch Screen Monitor

---



15.1" XGA Capacitive Touch Screen Monitor



**Specifications:**



General	Control button	Set Contrast ratio and Luminance via OSD t the back panel
	Dimensions (W x H x D)	371mm x 295mm x47mm (12.64" x 9.72" x 1.85")
	Cut out Size (W x H)	354mm x 278mm (13.94" x 10.94")
	Box structure	Front panel: aluminum-magnesium alloy, anodized coating ;Back over: SGCC, Ground isolation protection
	Mounting	Support panel mounted, wall-mounted, Desktop (VESA 75x75 & 100x100)
	Power Supply	DC 12-24V
	Power consumption	10W
	Signal input	VGA & DVI-D
	Weight	3.34kg ( 7.36lb )
LCD	LCD Size	15" XGA TFT
	Resolution	1024 x 768
	Colors	16.7MB
	Active Area (W x H)	304.13mm x 228.10mm (11.97" x 8.98")
	Backlight	LED
	MTBF	50000hrs
	Pixel Pitch(H x V)	0.099 x 0.297
	Luminance	350cd/m <sup>2</sup> or 420cd/m <sup>2</sup>
	Contrast Ratio	1000 : 1 or 800:1
	Viewing Angle	(L) 80 / (R) 80 / (T) 80 / (B) 80
Touchscreen	Type	Multi-point capacitive touch screen
	Transmittance	> 87%
	Controller interface	USB
	Driver Support	Windows XP, Windows 7, Winows8, Windows 10, Linux
	Multi-touch	10 points (windows system)
	Surface Hardness	Mohs' 7H
Environmental	Operating Temperature	-20 ~ 60° C (-4~140 °F )
	Storage Temperature	-30 ~ 80°C (-22 ~ 176 °F )
	Relative humidity	10~95% RH@40°C,non-condensing
	Vibration	Operating Random Vibration Test 5~500Hz, 1.5Grms@with SSD, follow IEC 60068-2-64
	Shock	Operating 10G peak acceleration (11ms duration), follow IEC 60068-2-27
	EMC	CE/FCC Class A
	Front panel protection	IP65 compliant

**Dimensions:**

Unit : mm

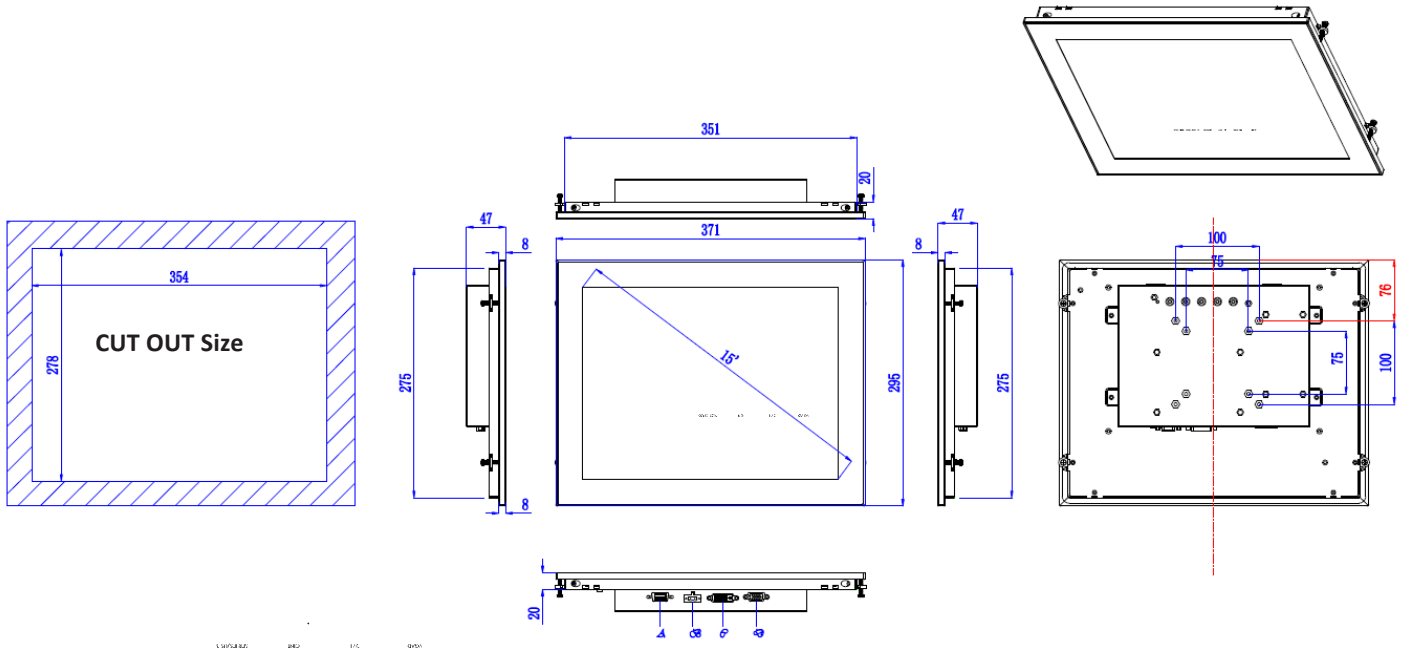

A:USB	B:DC IN	C:DVI	D:VGA
-------	---------	-------	-------

**Ordering Information:**

Product Code	Description
PANEL5000-C152-L	15" TFT LCD / 1024*768 / 1xVGA / 1xDVI / Capacitive Touch Screen/DC12-24V input

**Packing List:**

Mounting screws	4pcs, Thickness=1mm~1.2mm
Terminal	2pin Phoenix terminal
VGA Cable	1.8M
USB Cable	1.8M

**Optional Items:**

Adapter	12V/3.33A,40W 2pin Phoenix terminal
Power Cord	1.8M/3M/5M
VGA Cable	3M/5M
USB Cable	3M/5M
DVI Cable	1.8M/3M/5M